

UNICEF Design System
Visual Guidelines
v0.4.0



Disclaimer

This document is in DRAFT status and may be subject to changes.

This document is mainly intended for internal use of UNICEF staff and partners.

Colors

Brand

The following are defined in UNICEF's brand book:

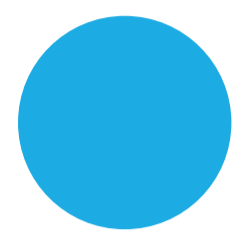

#1CABE2 (`$unicef-blue`)

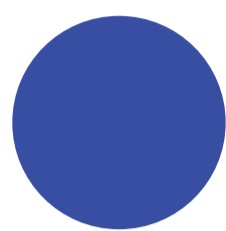

#374EA2 (`$unicef-dark-blue`)

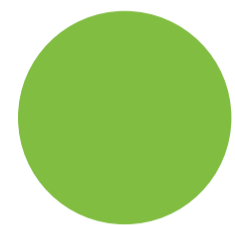

#80BD41 (`$unicef-green`)

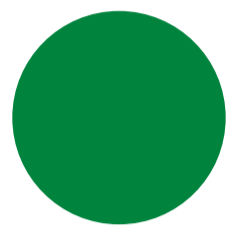

#00833D (`$unicef-dark-green`)

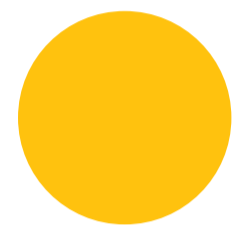

#FFC20E (`$unicef-yellow`)

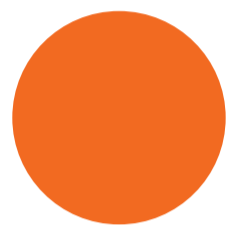

#F26A21 (`$unicef-orange`)

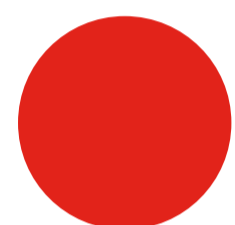

#E2231A (`$unicef-red`)

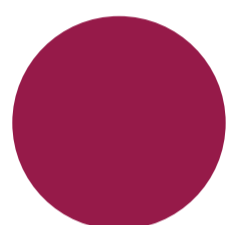

#961A49 (`$unicef-dark-red`)

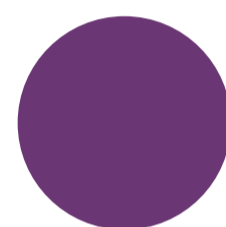

#6A3674 (`$unicef-purple`)

Grayscale



#F4F4F4 (`$background`)



#C9C9C9 (`$borders`)

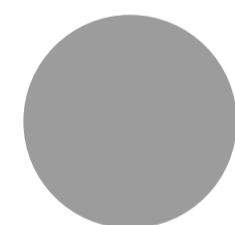

#9C9C9C (`$muted`)

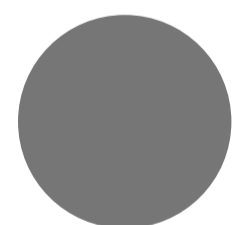

#767676 (`$lighter`)

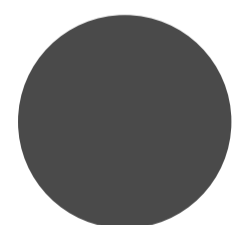

#4A4A4A (`$default`)

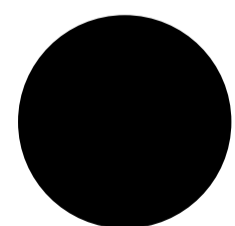

#000000 (`$black`)

Links



#3344DD (`$unicef-link`)

Background colors

Page backgrounds

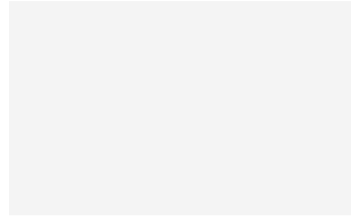

#F4F4F4 (`$background`)



#FFFFFF (`$white`)

Field backgrounds

Mandatory fields



(`=mix(white, $warning, 88%)`)

Fields with error



(`=mix(white, $danger, 96%)`)

Colors

Traffic light colors

These colors are used to represent status of an action or an element.



#80BD41 (`$success = $unicef-green`)

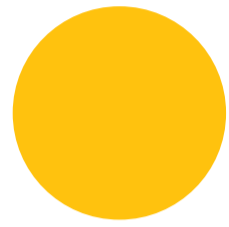

#FFC20E (`$warning = unicef-yellow`)

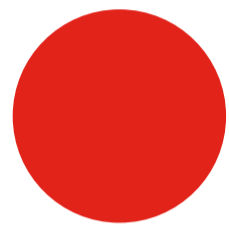

#E2231A (`$danger = unicef-red`)

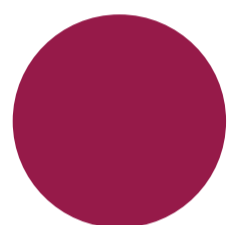

#961A49 (`$dark-danger = unicef-dark-red`)

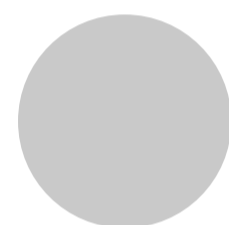

#C9C9C9 (`$disabled = $borders`)

Traffic light backgrounds

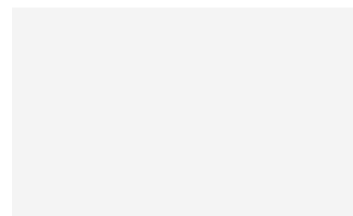

(`$background`)

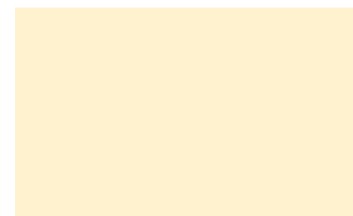

(`= mix(white, $warning, 80%)`)

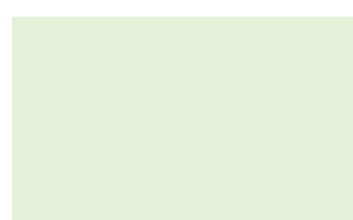

(`=mix(white, $success, 80%)`)



(`= mix(white, $danger, 80%)`)

Color shall not be used as the only visual means of conveying information, indicating an action, prompting a response, or distinguishing a visual element.

UNICEF Logos

unicef  | for every child

unicef  | for every child

unicef 

for every child

unicef 

for every child

unicef 

unicef 

Grid system

Columns

We use a 12 column system with a gutter (space between two columns) of 16px.

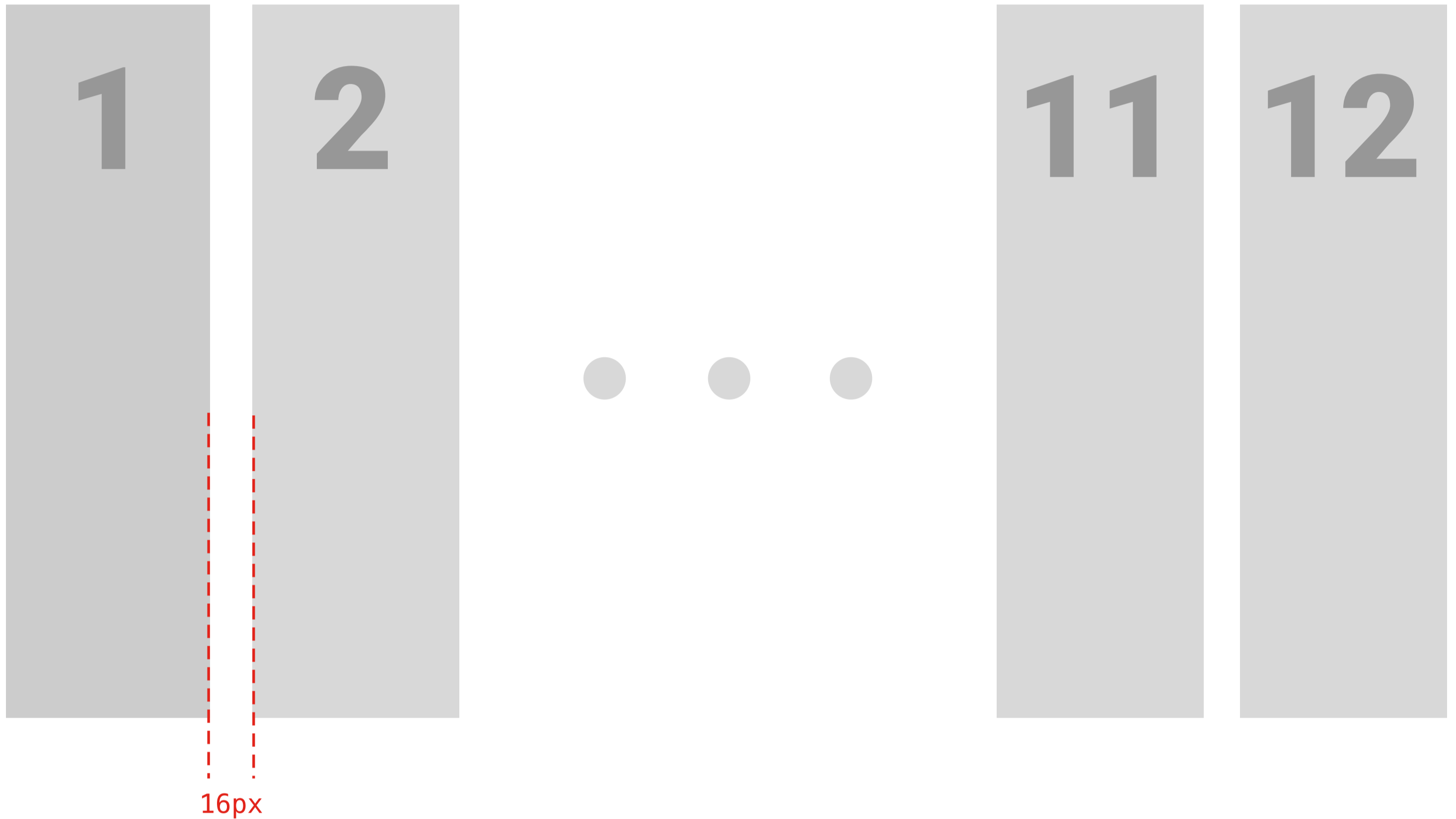

We will assume that the grid works the same way it does in the Bootstrap framework.

Columns are enclosed within containers. These are the containers for each breakpoint: sm: 540px, md: 720px, lg: 960px, xl: 1140px.

Vertical flow

For vertical flow, we use by multiples of **0.5rem (8px)**. Each element total height shall be always a multiple of 8px or 0.5rem.

Generally, browsers set **1rem = 16px**. Therefore, 0.5rem is equivalent to 8px.

Typography

We use the native font stack.

```
$font-family-sans-serif:  
  -apple-system,                // Safari for OS X and iOS (San Francisco)  
  BlinkMacSystemFont,          // Chrome < 56 for OS X (San Francisco)  
  "Segoe UI",                  // Windows  
  "Roboto",                     // Android  
  "Helvetica Neue", Arial, sans-serif, // Basic web fallback  
  "Apple Color Emoji", "Segoe UI Emoji", "Segoe UI Symbol" !default; // Emoji fonts
```

Texts

Common properties for default texts

```
line-height: 1.5rem; //24px  
font-size: 1.0rem; //16px
```

Default Text = Common + default color.

Lighter text (muted) = Common properties + color lighter

Semibold = Common properties + color black + semibold

Strong = Common properties + bold + color black

Small

Common properties for small texts

```
line-height: .67rem; //16px  
font-size: 0.75rem; //12px
```

small text

Lighter text (muted)

small strong

Labels and Placeholders

Labels use \$default color \$lighter color. Placeholder too. Both need to be accessible.

Input with placeholder

Headings

Common properties for headers:

```
margin-top: 1.5rem; //24px  
margin-bottom: 0.5rem; //8px  
color: black;
```

h1. Heading 1

Font weight bold, font size 1.5 rem and line height 3 rem. Lorem ipsum dolor sit amet, consectetur adipiscing elit. Etiam non ligula et erat laoreet hendrerit quis vitae ante. Mauris tincidunt dapibus erat eget tempus. Integer blandit, tellus sed dapibus rhoncus, dui tortor congue urna.

h2. Heading 2

Font weight semibold, font size 1.25rem, line height 2.75 rem. Lorem ipsum dolor sit amet, consectetur adipiscing elit. Etiam non ligula et erat laoreet hendrerit quis vitae ante. Mauris tincidunt dapibus erat eget tempus. Integer blandit, tellus sed dapibus rhoncus, dui tortor congue.

h3. Heading 3

Font weight semibold, font size 1rem, line height 2 rem. Lorem ipsum dolor sit amet, consectetur adipiscing elit. Etiam non ligula et erat laoreet hendrerit quis vitae ante.

h3. Heading 4

Font weight bold, font size 0.875rem, line-height 1.25 rem. Lorem ipsum dolor sit amet, consectetur adipiscing elit. Etiam non ligula et erat laoreet hendrerit quis vitae ante.

Alerts

Alerts appear as **result of an action**. Common properties for alerts:

```
padding: 0.75rem 1.25rem; // 12px top/bottom and 20px left-right  
line-height: 1.5rem; // Ends up with a min height of 24 + 12 + 12 = 48  
color: darker +
```

This is a success alert. Helps to inform that there was some task that was successfully completed.

This is a warning alert. Helps to provide the user some information that is important for him to know.

This is a danger alert. Helps to provide the user some information that is important for him to know.

This is an alert. Alerts can have a **bold** text. And [even links](#).

This is an alert that can be dismissed

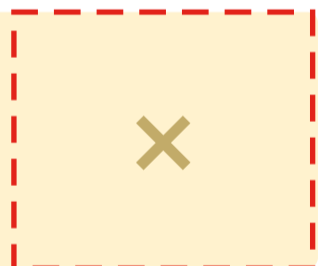

Clickable button
padding: 0.75rem 1.25rem //12px 20px font-size: 1.5rem; //24px
line-height: 1.5rem; font-family: Arial;

```
:hover {  
  cursor: pointer;  
  color: $black;  
}
```

Icons

For general icons we use FontAwesome 5.x, for UN/Humanitarian representations we use the Humanitarian font.

FontAwesome:

<http://www.fontawesome.com>

Humanitarian font:

<https://reliefweb.int/report/world/world-humanitarian-and-country-icons-2012>



<https://github.com/lubar/Humanitarian-Icons-WebFont>

All icons shall include a label as it is more accessible. Exceptionally, a :hover tooltip



Please, see the Designer Guidelines to know more about the standardized use of icons.

Cursors

-  default: It shall be the default cursor.
-  text: Cursor for all active editable fields (input, textareas, etc..), as well as selecteable text.
-  pointer: All clickable/actionable elements must have the hand cursor.

Note these cursos slightly vary depending on the operating system.













Buttons and Links

Buttons are used for performing actions on the interface.

Common properties for buttons

```
min-width: 88px;  
border-radius: 2px;  
font-size: 0.875rem; //14px  
font-weight: 600; //Semibold  
text-transform: uppercase;
```

```
padding-left: 1rem; //16px  
padding-right: 1rem;  
padding-top: 0.5rem;  
padding-bottom: 0.5rem;  
line-height: 1.5rem; //Total height is 40px
```

	Default Button	Primary Button	Danger Button
normal			
:hover			
:active			
:disabled			 → opacity: 50%

Buttons with Icons

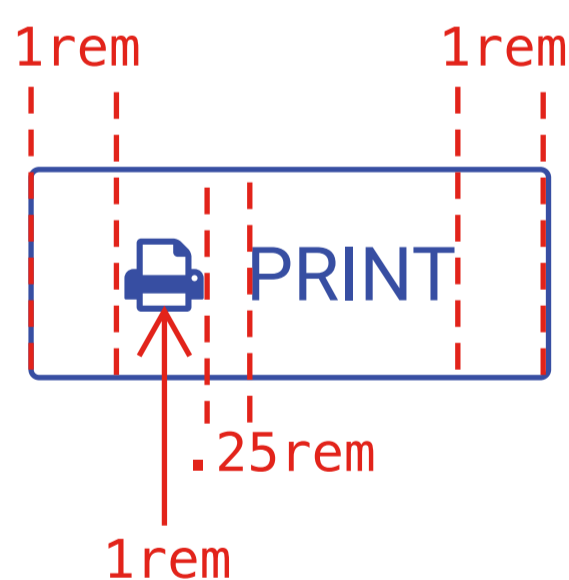

Mobile

Mobile buttons have a slightly large height to allow user to tap on them.



```
padding-top: 0.75rem; //  
padding-bottom: 0.75rem; //Total height 48px;
```

Links

normal **:hover** **:active** **:visited** **Disabled**
[Link](#) [Link](#) [Link](#) [Link](#) Link

Link variants [Link within](#) [Link within <small>](#)

Repeating links (e.g. in a list or a table) should not have an underline

Main Element	Date	Amount (USD)
Text is a link	29-May-2018	\$23.33
This is another link. Vertically align cells to the middle	12-Aug-2017	\$99.44
Text is left-aligned	29-May-2018	\$1,223.00

Focus

For accessibility all elements that have an action shall display by default the following style when the **:focus** status is active.

[Link](#)

Item with action in dark bg

BUTTON

Dropdown menus

Any item that is marked with the caret down symbol, has a dropdown.

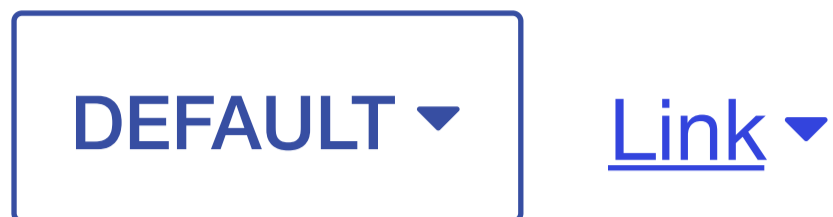

All dropdowns shall have the same look & feel. There may be exceptions as in <select> element.

When dropdown is displayed the item with the caret shall have the active status.

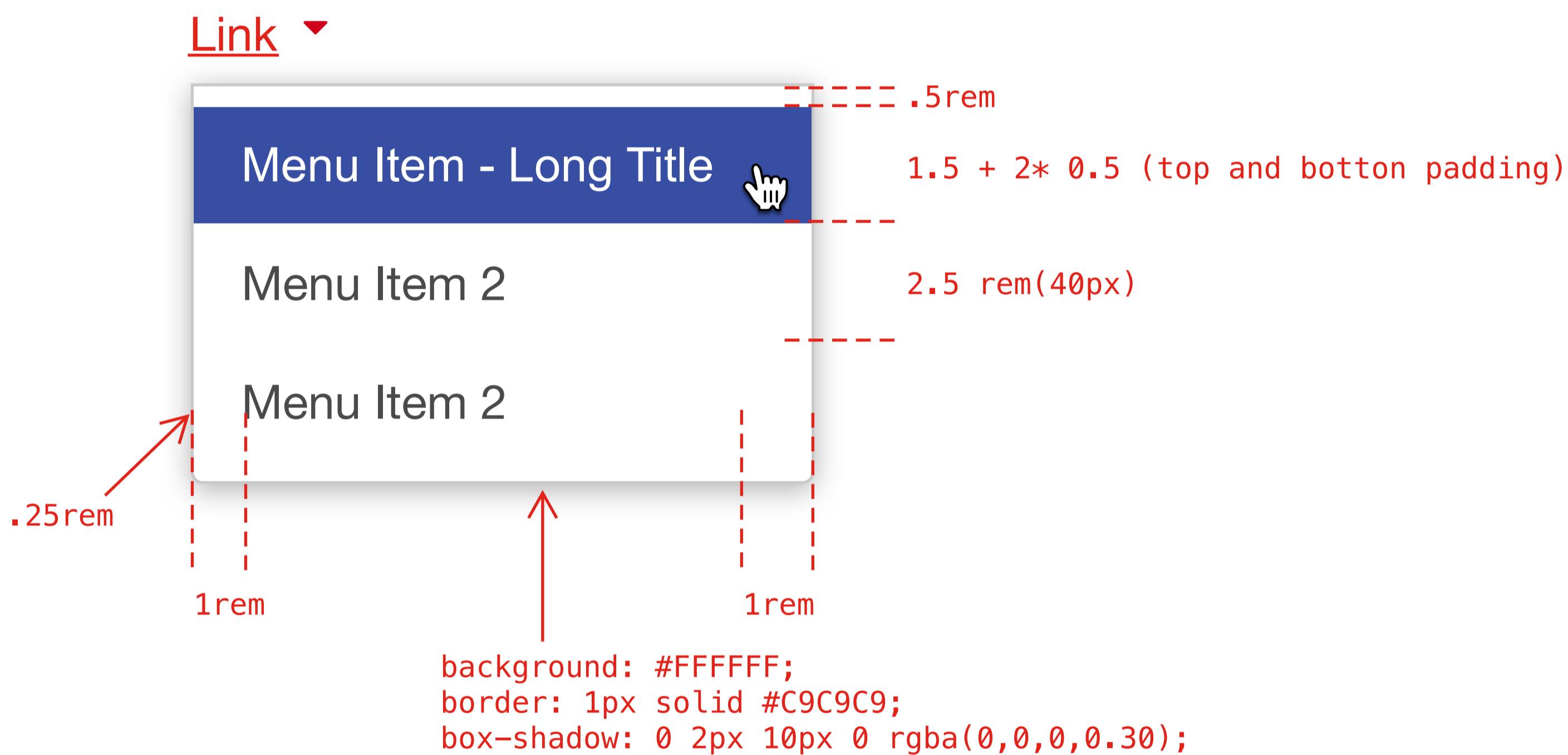

Forms

Input

Input with placeholder

Mandatory field *

Input with content

Mandatory field with data *

Form element Disabled

Read only field

Text

Textarea

Mandatory textarea with placeholder *

2,028 characters remaining

Label *

2,028 characters remaining

Label *

1,958 characters remaining

Selects

Select with placeholder

Forms

Input with hint

If the field has a hint it is always visible.

Form with errors

Label*

This is an error that has more than one line

Label*

This is an error

Search box

Search box

Search box with other elements

 [Link](#)

App header

Desktop >1024px



Tablet <= 1024px

Hides UNICEF logo.



Accessibility: Skip navigation link has :focus

For users that navigate with keyboard. Skip navigation link shall be provided. This link is only in a visible area when it has the focus.

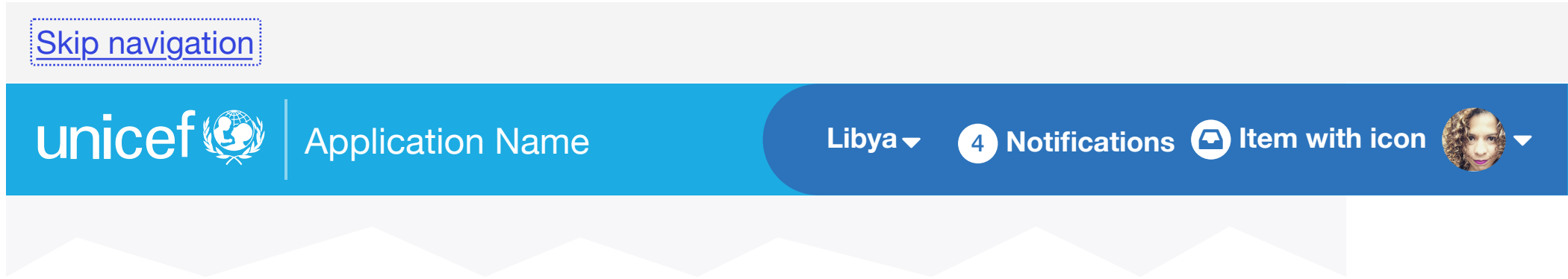

Accessibility: Skip navigation link has :focus (fixed header)

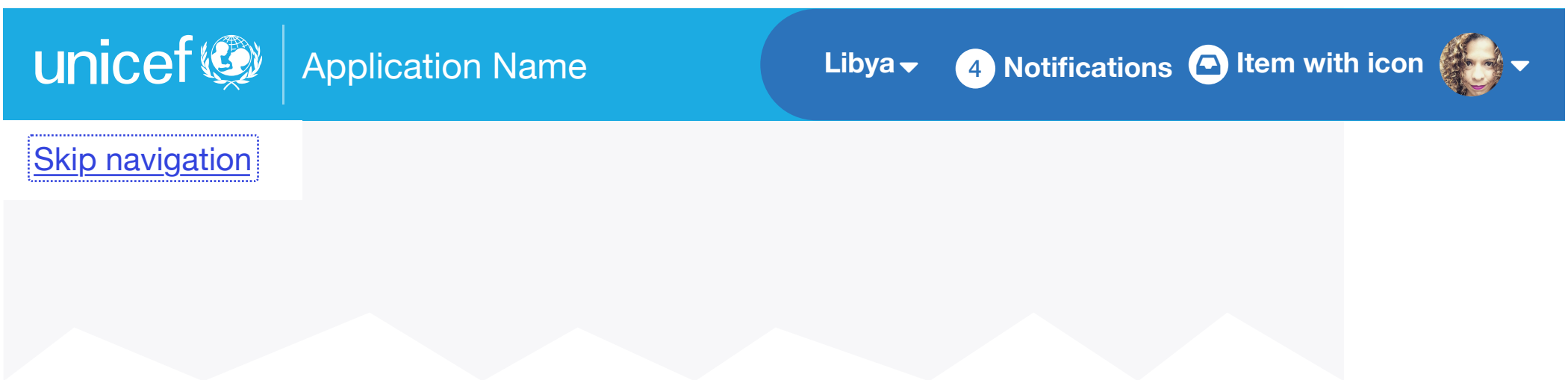

App header with menu

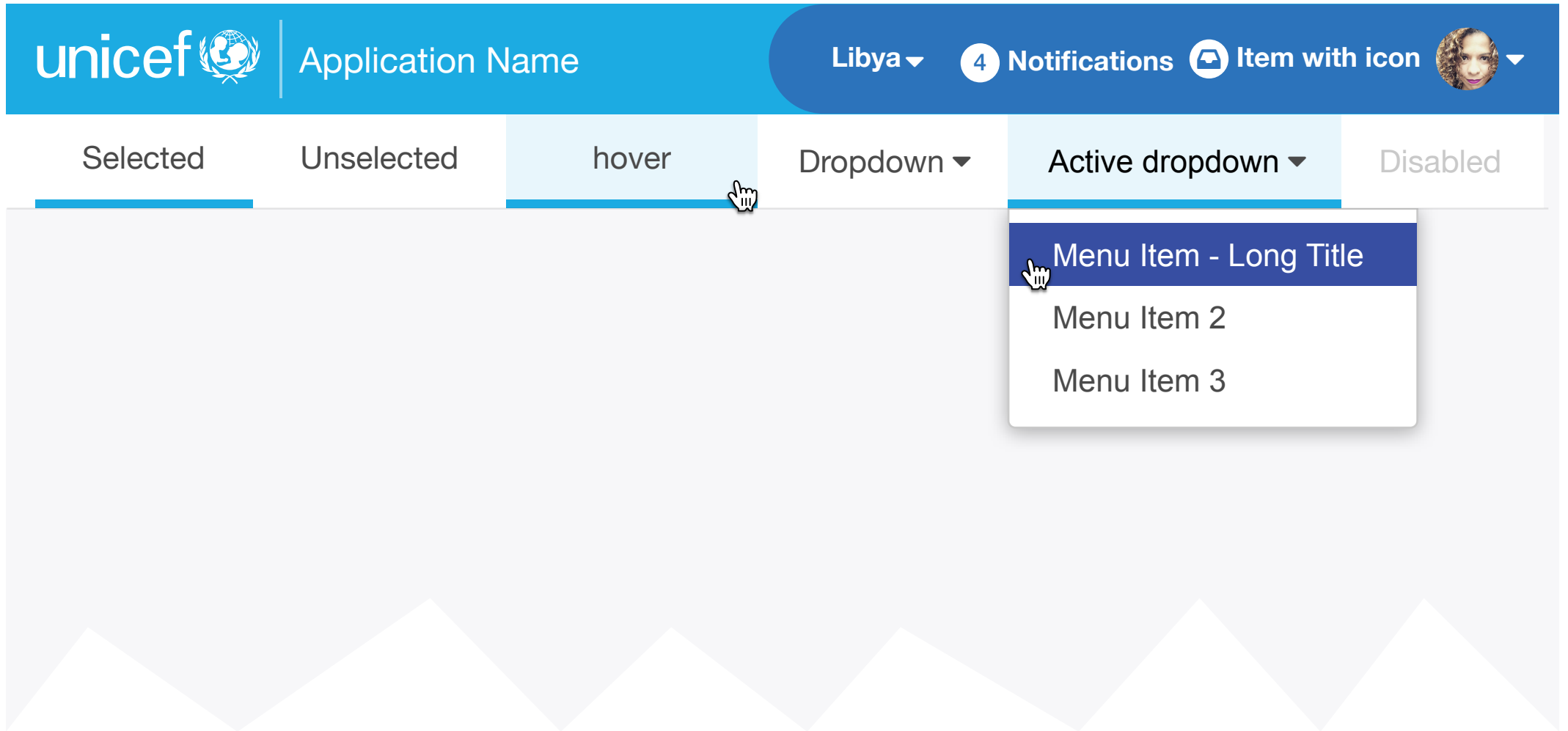

Mobile (Experimental TBD)

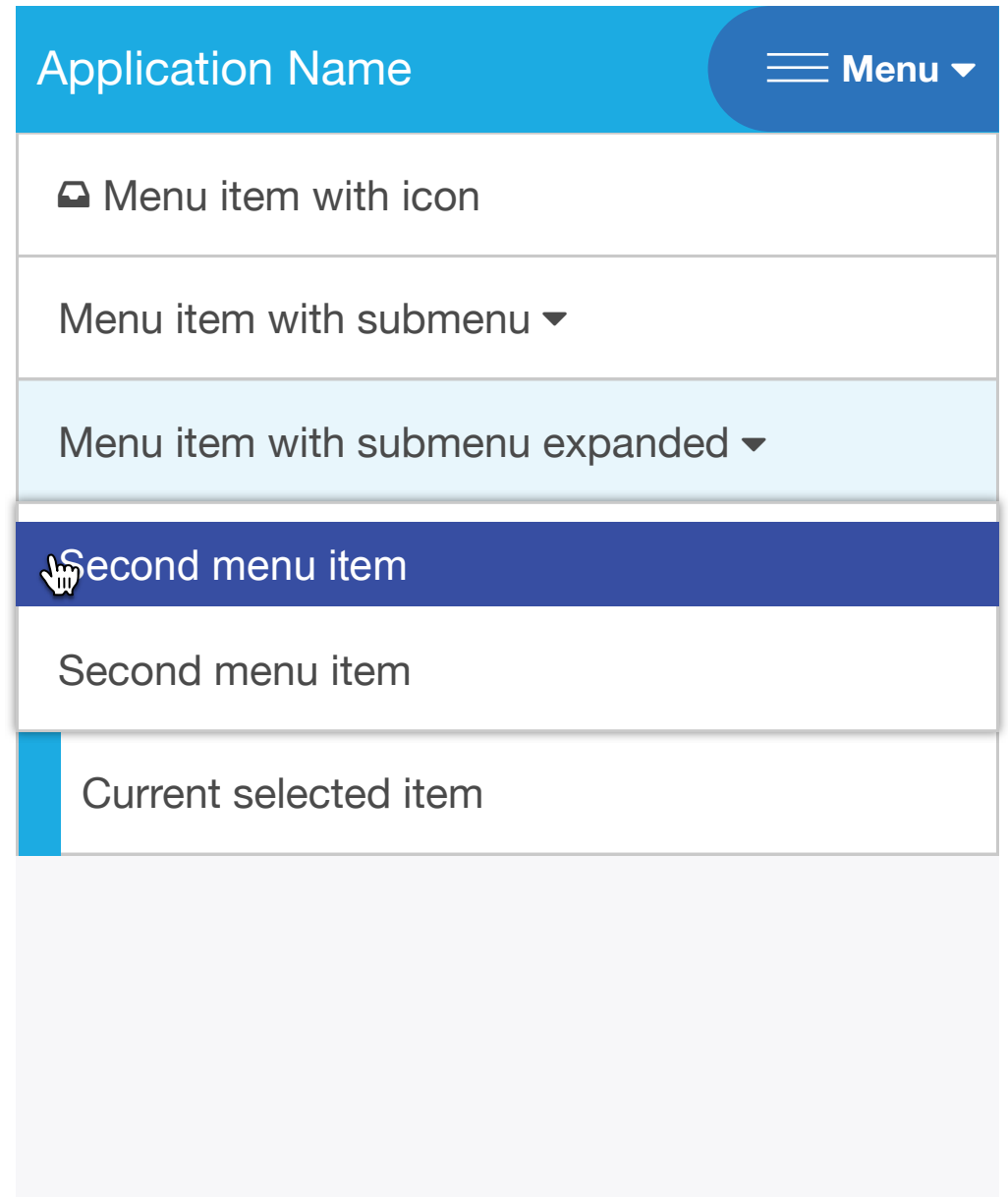
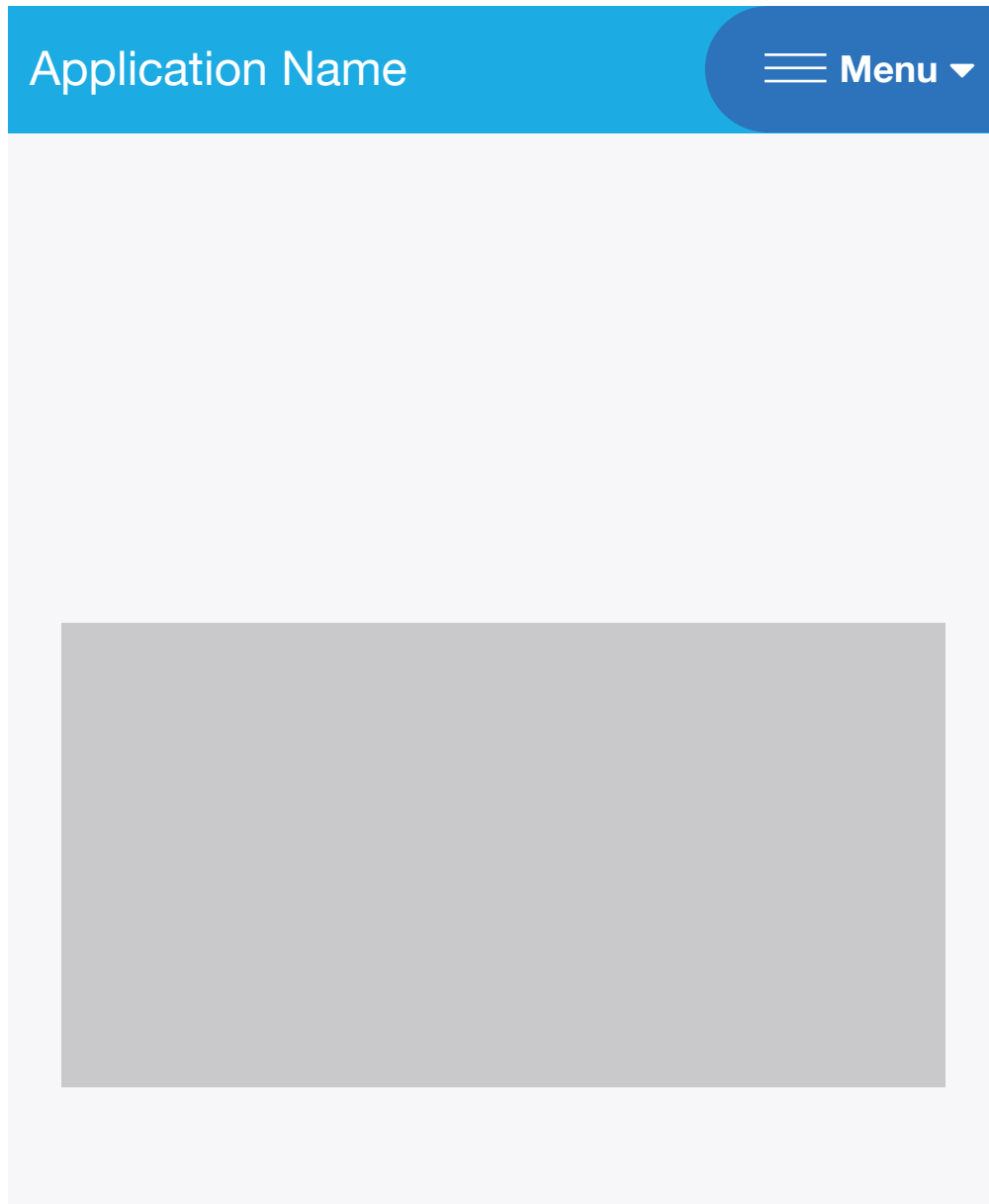

Navigation - Tabs

```
min-width: 100px;  
line-height: 1.5 rempx;  
padding: 12px 16px;
```

Selected

Normal



hover

Disabled

Tab Heading

Tab content has an internal padding of 16px

Navigation - Trees

▼ [Level 1](#)

▼ [Level 2](#)

▶ [Level 3](#)

▶ Level 3 with a long
name

– [Level 3 with no
children](#)

– Level 3 with no
children nor

Selected node

Node with hover

Node without children

Node no children disabled

Tables

Main Element	Amount (USD)	Date	Risk
Text is left-aligned	23.33	29 May 2018	● Medium
Generally vertically align cells to the middle	-99.44	12 Aug 2017	● Low
Numbers are right aligned	1,223.00	29 May 2018	● High



Cards

Card with actions menu

 [Actions](#) ▼

Lorem ipsum dolor sit amet, consectetur adipiscing elit. Duis ut diam ex. Suspendisse quis quam volutpat, lobortis nisi non, mattis mauris. Integer placerat, diam vitae malesuada ultricies, lacus mi congue lacus, eget congue turpis lacus sit amet dolor.

[Read more](#)

Card Head

Lorem ipsum dolor sit amet, consectetur adipiscing elit. Duis ut diam ex. Suspendisse quis quam volutpat, lobortis nisi non, mattis mauris. Integer placerat, diam vitae malesuada ultricies, lacus mi congue lacus.

[Read more](#)

Selected

Normal

Cards with navigation tabs inside.

User can select each tab.

Card without head block

Lorem ipsum dolor sit amet, consectetur adipiscing elit. Duis ut diam ex. Suspendisse quis quam volutpat, lobortis nisi non, mattis mauris. Integer placerat, diam vitae malesuada ultricies.

Progress bar

Default width = 100% of container width.

Fully empty (current_value <= 0)



Partially filled



Without numbers



Annex - Exportable Resources

